

PG56(for step motor)



Note:

- 1、外壳材质(Housing material): metal
- 2、背隙, 无负荷时 (Backlash, at no-load) : $\leq 1.2^\circ$
- 3、轴承型号 (Bearing at output) : ball bearings
- 4、径向间隙 (Radial play of shaft) : $\leq 0.05\text{mm}$
- 5、轴向间隙 (Thrust play shaft) : $\leq 0.3\text{mm}$

外形尺寸图/Appearance size

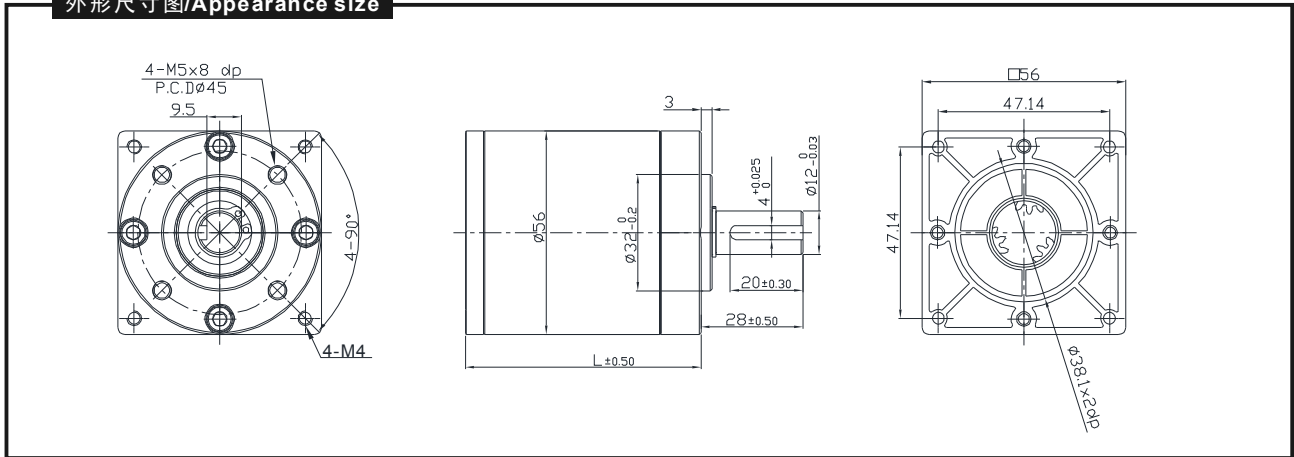

马达装卸方法/Motor Installation

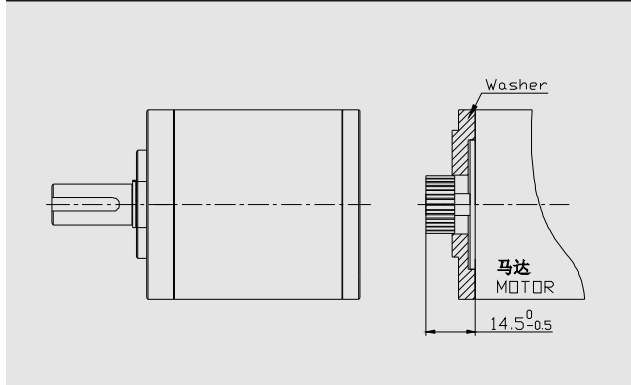

马达齿轮参数/Pinion Specifications

模数 Module	1.0	1.0
齿数 NO. of teeth	12	15
压力角 Pressure angle	20°	
孔径 Hole diameter	Φ5.97	Φ5.97, Φ7.96
减速比 Reduction ratio	4.3, 22.7, 121, 276, 326, 409, 514, 1567, 2321, 3439	3.6, 13, 19.2, 46.7, 69, 102, 198, 843, 995, 1966

使用温度范围/Operating temperature range: $-10^\circ\text{C} \sim +60^\circ\text{C}$

使用相对湿度/Operating relative humidity: 20%~85%RH

标准减速比参数/Gearboxes Specifications

减速比 Reduction ratio	精确减速比 Reduction absolute	额定允许扭力 Rated tolerance torque	极限扭矩 Max breaking torque	效率 Efficiency	级数 Number of stages	齿轮箱长度 Gearbox length "L" mm
3.6, 4.3	3 3/5, 4 1/4	50.0kgf · cm	150.0kgf · cm	90%	1	37.1
13, 19.2, 22.7	12 24/25, 19 1/5, 22 2/3	100.0kgf · cm	300.0kgf · cm	81%	2	51.0
46.7, 69 102, 121	46 82/125, 69 3/25 102 2/5, 120 8/9	200kgf · cm	600kgf · cm	73%	3	64.9
198, 276, 326, 409, 513	198 36/125, 276 57/160 326 65/256, 409 5/12, 513 7/9	200kgf · cm	600kgf · cm	65%	4	78.8
843, 995, 1567 1966, 2321, 3439	842 18/25, 994 353/400, 1566 18/25, 1966 2/25, 2321 1/15, 3438 50/81	200kgf · cm	600kgf · cm	59%	5	95.2